



EMANUEL S.r.l.

Via G. Marconi, 3 - 40011 Anzola Emilia (BO) – ITALY

☎ (+39) 051-732652

☎ (+39) 051-734001

✉ info@emanuel.it

🌐 www.emanuel.it

ERGONOMIC POSITIONER

model	F Ton	C1 N*m	n1 max min ⁻¹	V _{full load} cm/min	D mm	A mm	B mm	C mm	P1 kW	P2 kW
STR 20M	2	3000	1	56	600	350	1550	1900	0,75	1,85
STR 40M	4	3500	1,4	56	600	350	1550	1900	0,55	1,85
STR 50M	5	4000	1	56	750	400	1550	1950	0,55	1,85

FIXED MASTER COLUMN

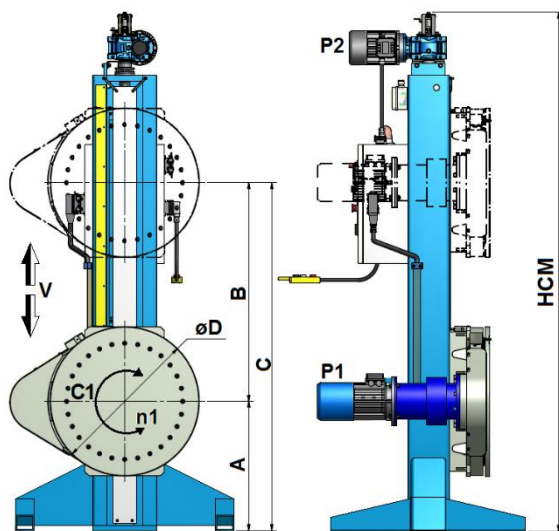

MOBILE SLAVE COLUMN

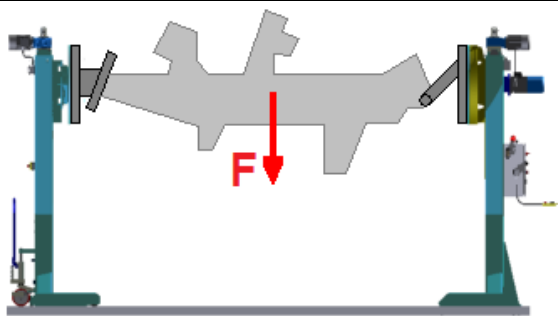
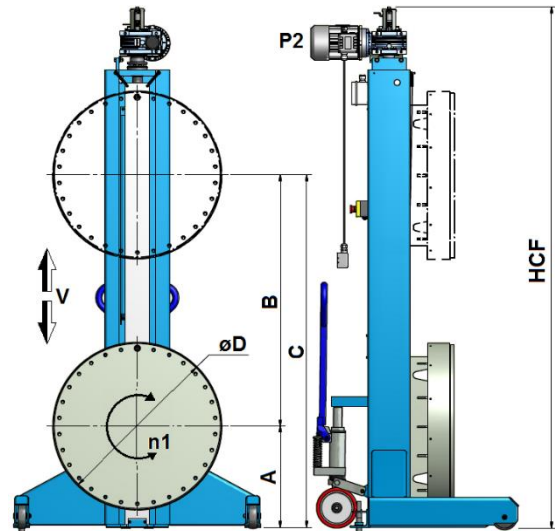

Model	HCM (mm)	Master column Weight (kg)	HCF (mm)	Slave column Weight (kg)
STR 20M	2500	610	2500	460
STR 40M	2500	600	2500	500
STR 50M	2500	600	2500	500

STR 20 – MAX CAPACITY 2 TON – MAX TORQUE 3.000 Nm

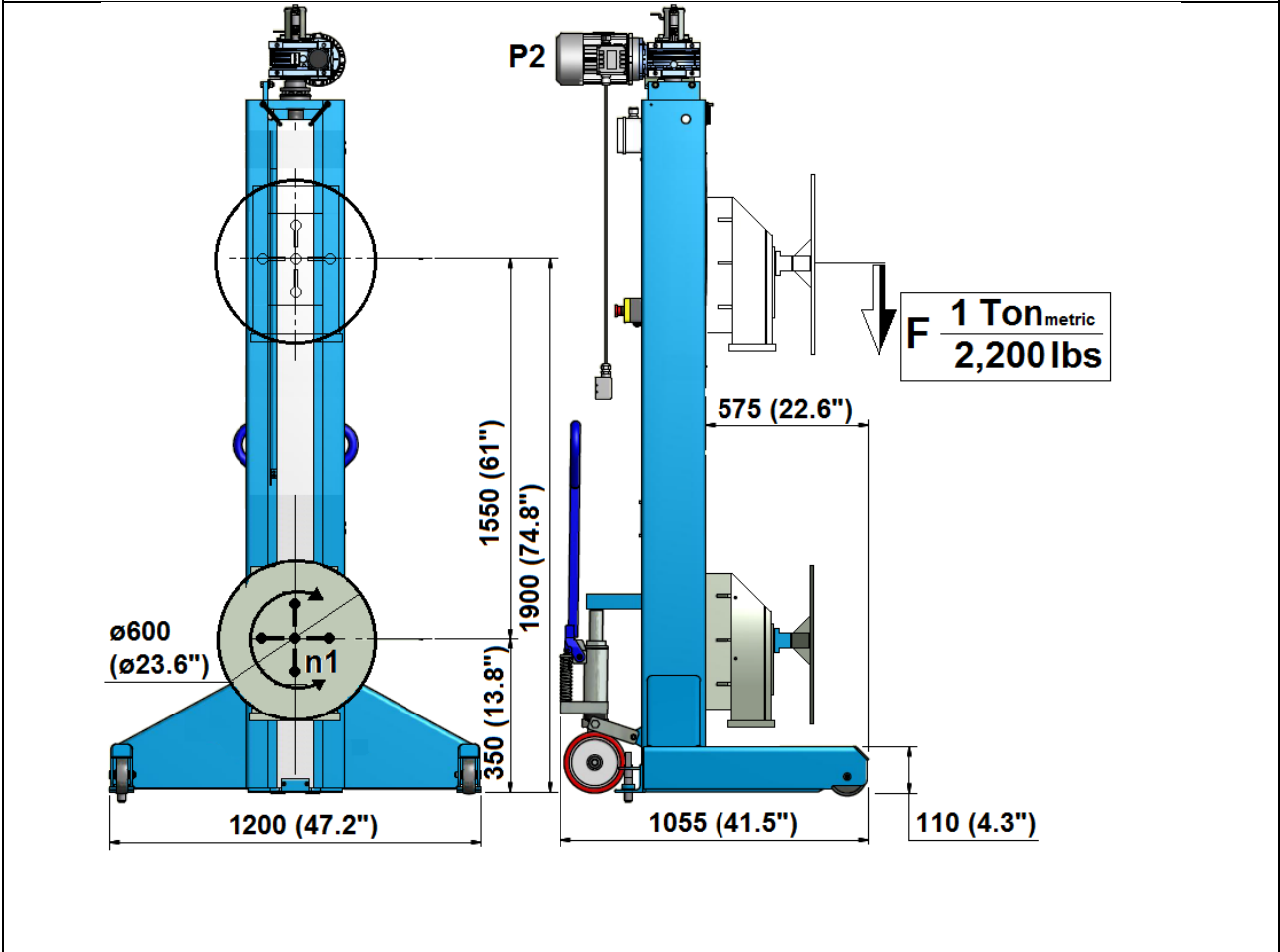
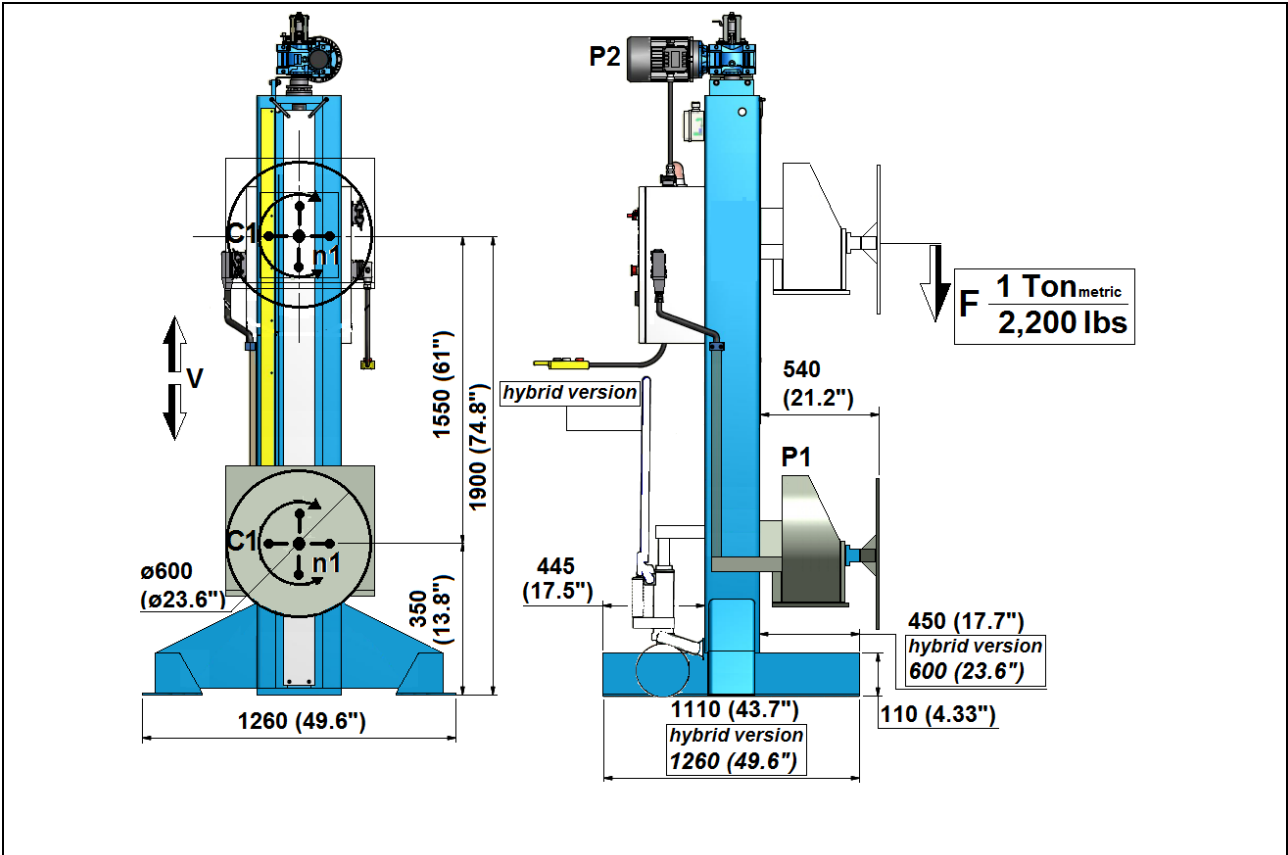

STR 40 – MAX CAPACITY 4 TON – MAX TORQUE 3.500 Nm

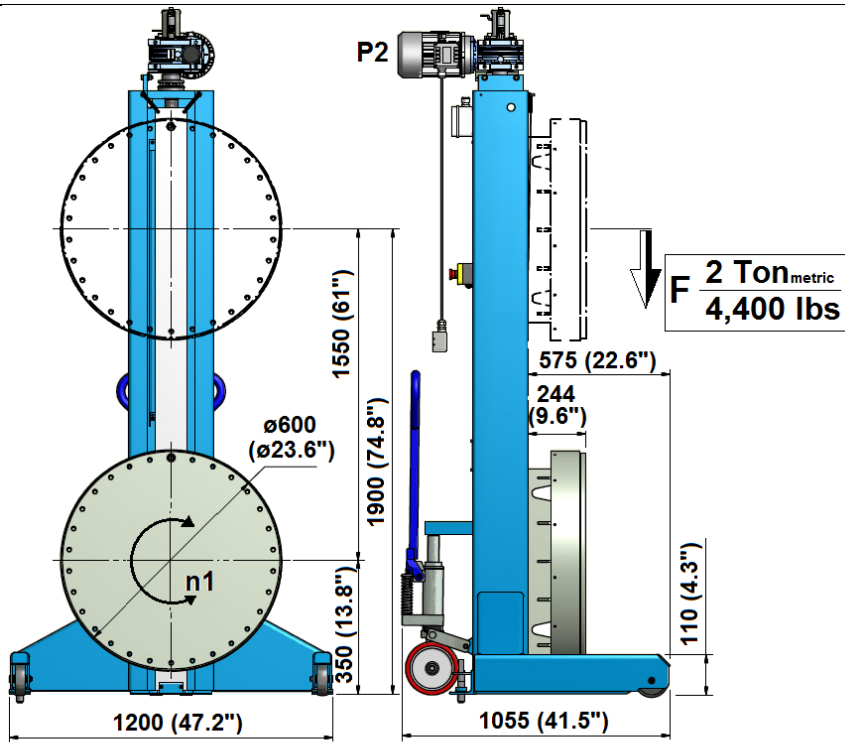
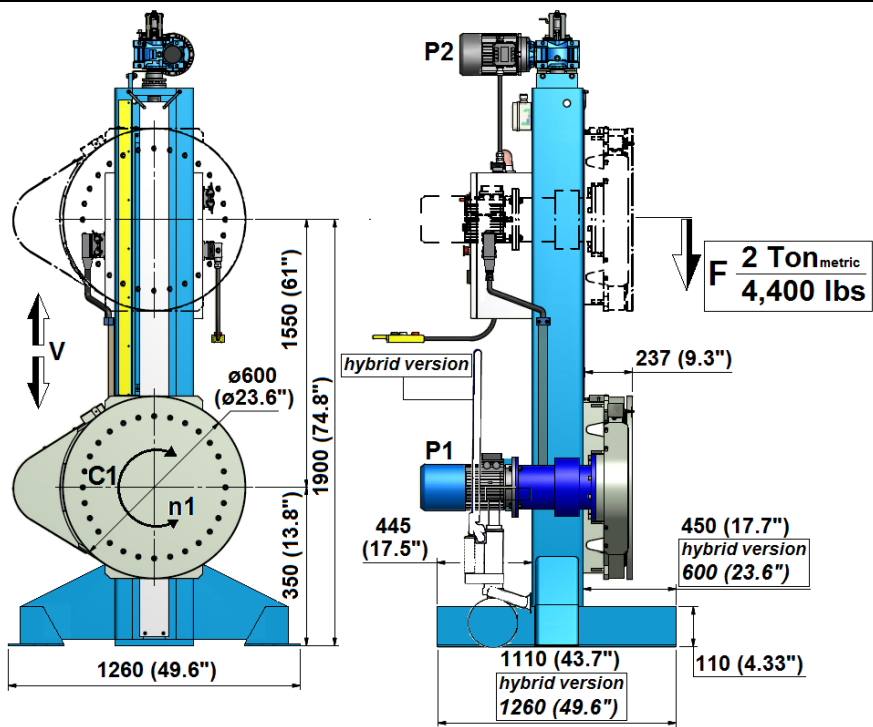

STR 50 – MAX CAPACITY 5 TON – MAX TORQUE 4.000 Nm

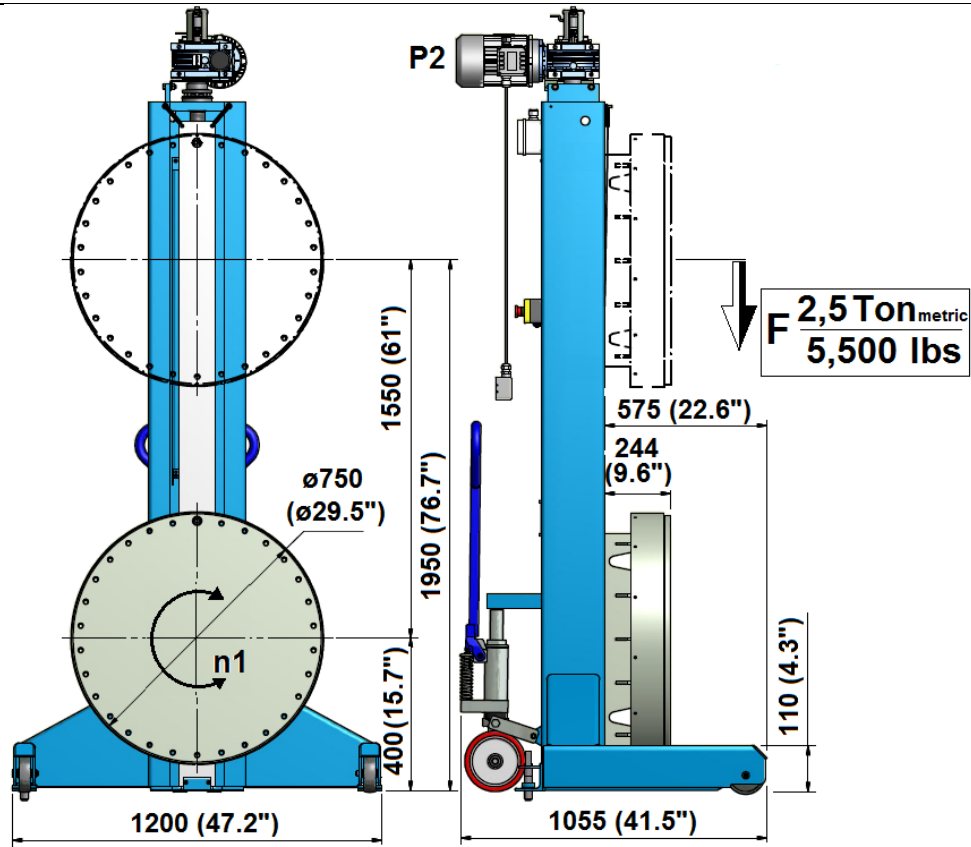
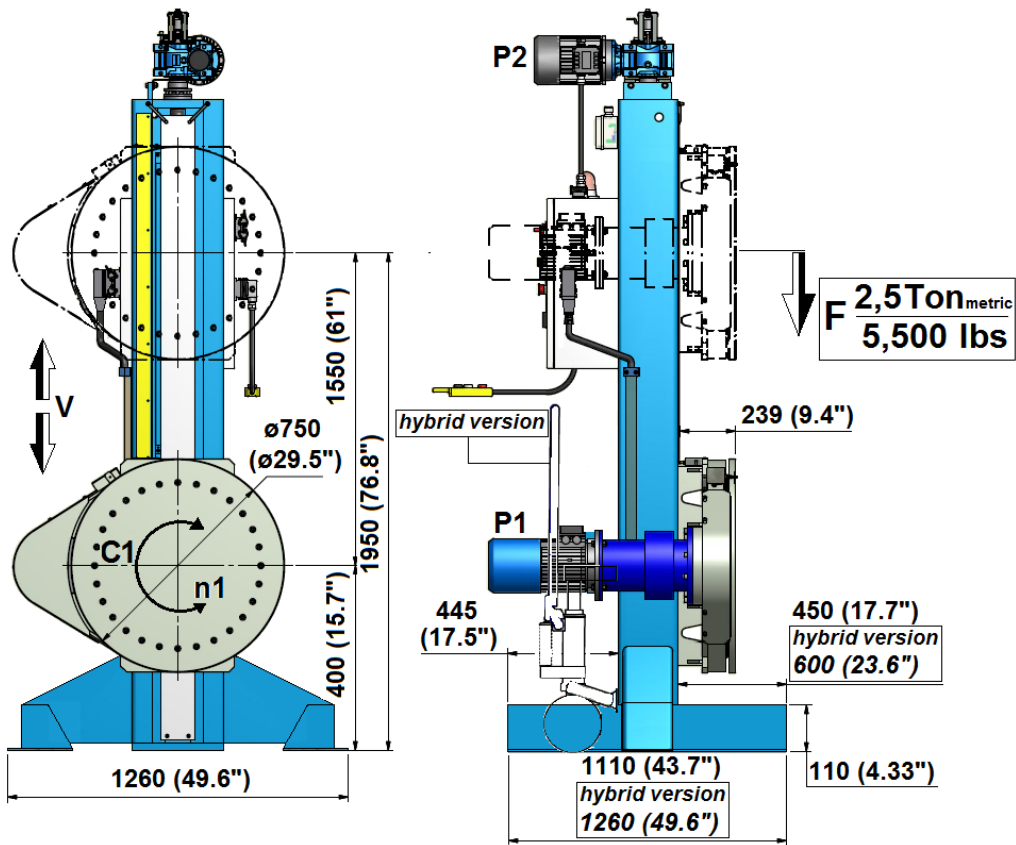

SIMILAR EQUIPMENT DESIGNED FOR OTHER CUSTOMERS.

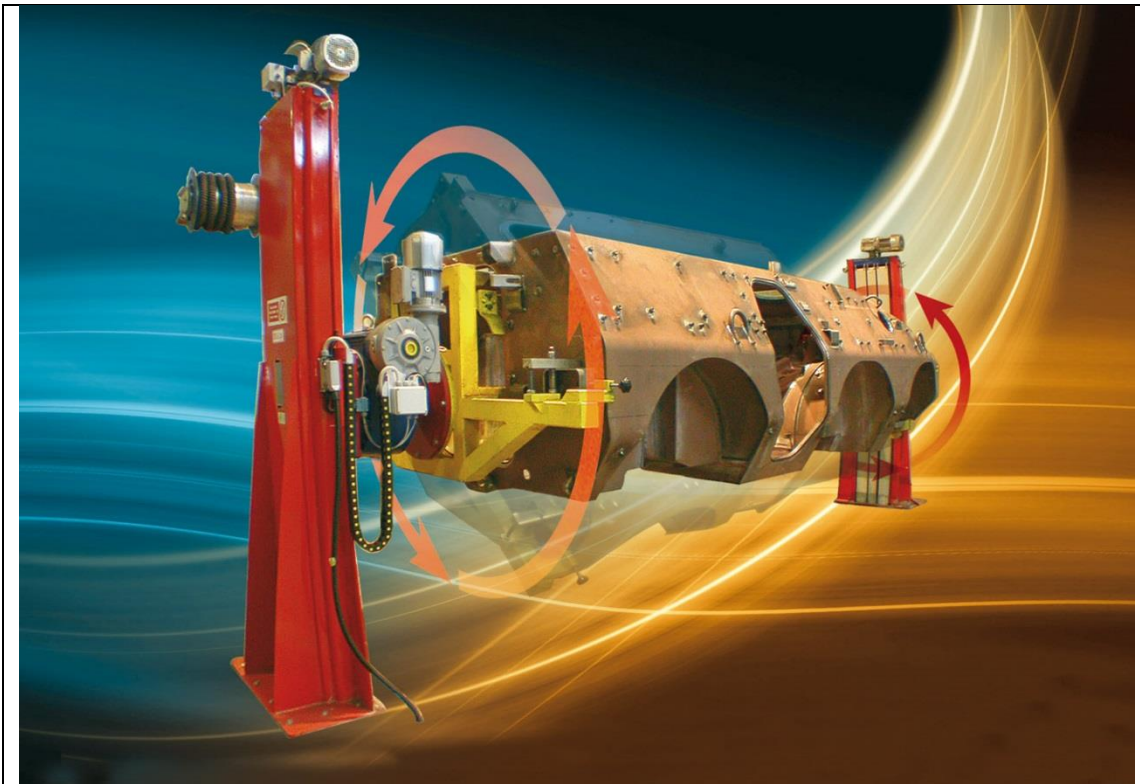

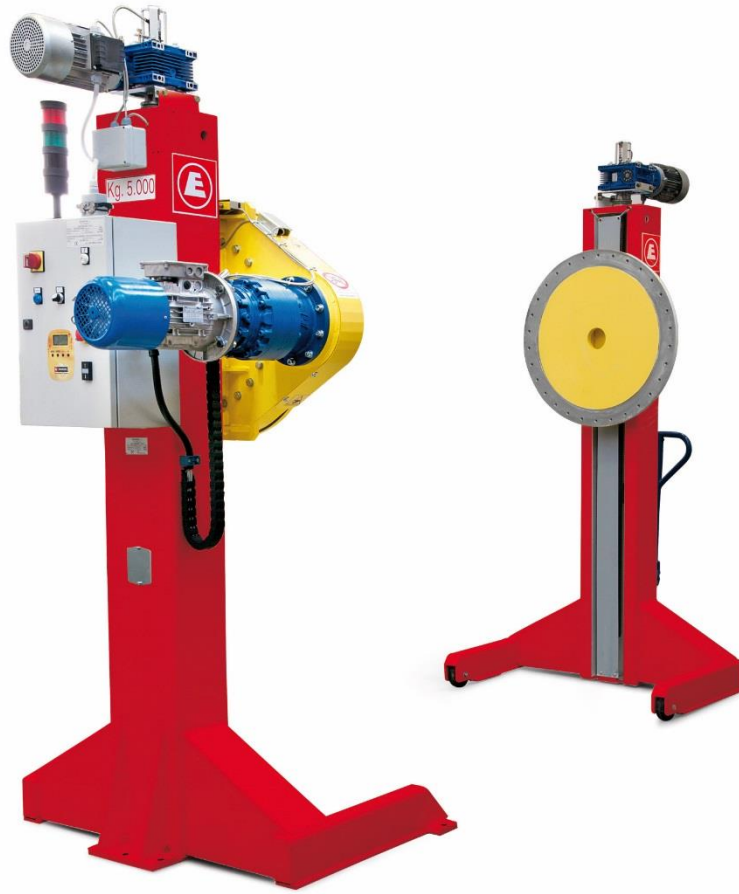

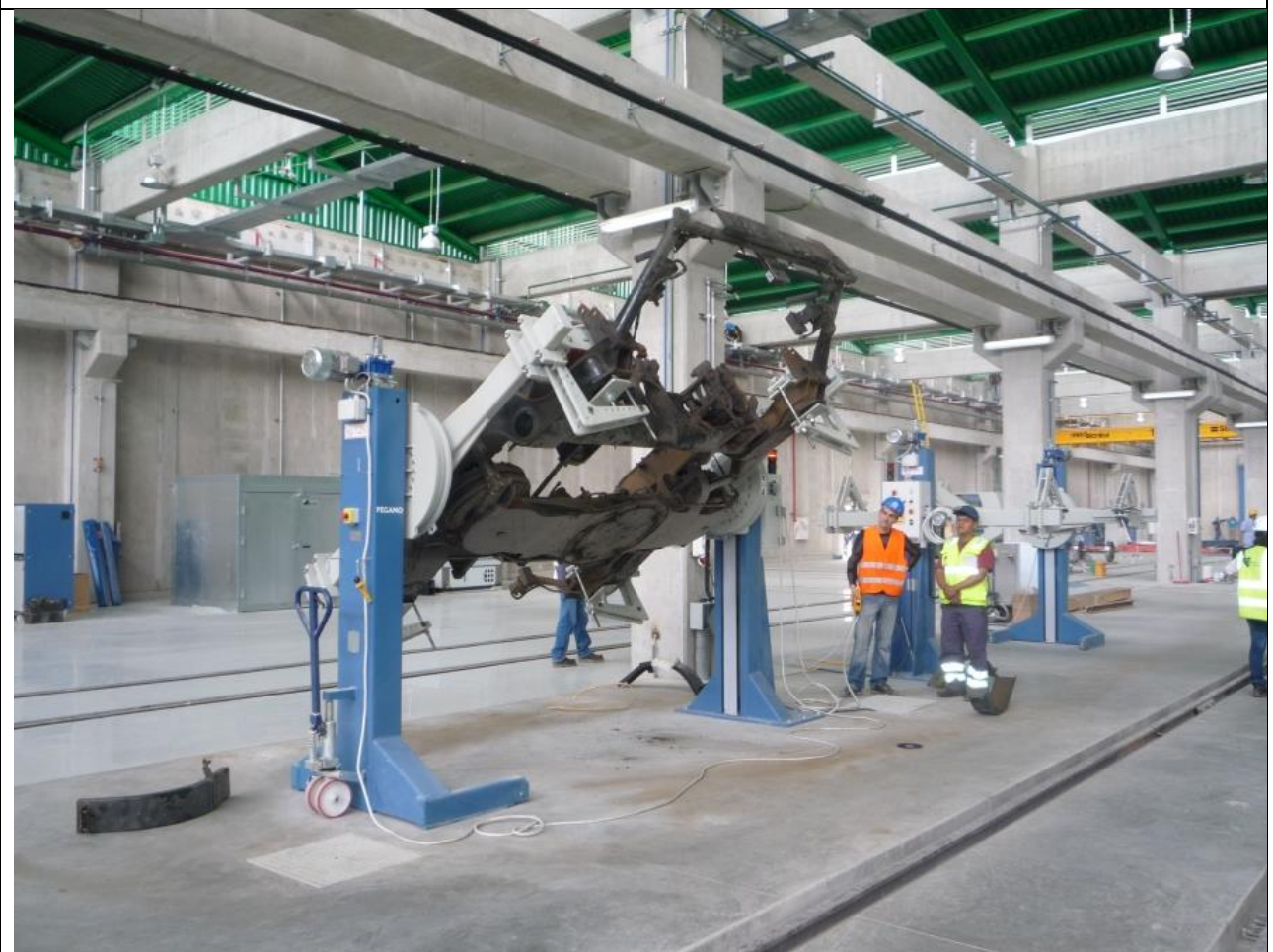



DETAIL OF MOTORIZED SLEWING BEARING ON MASTER JACK

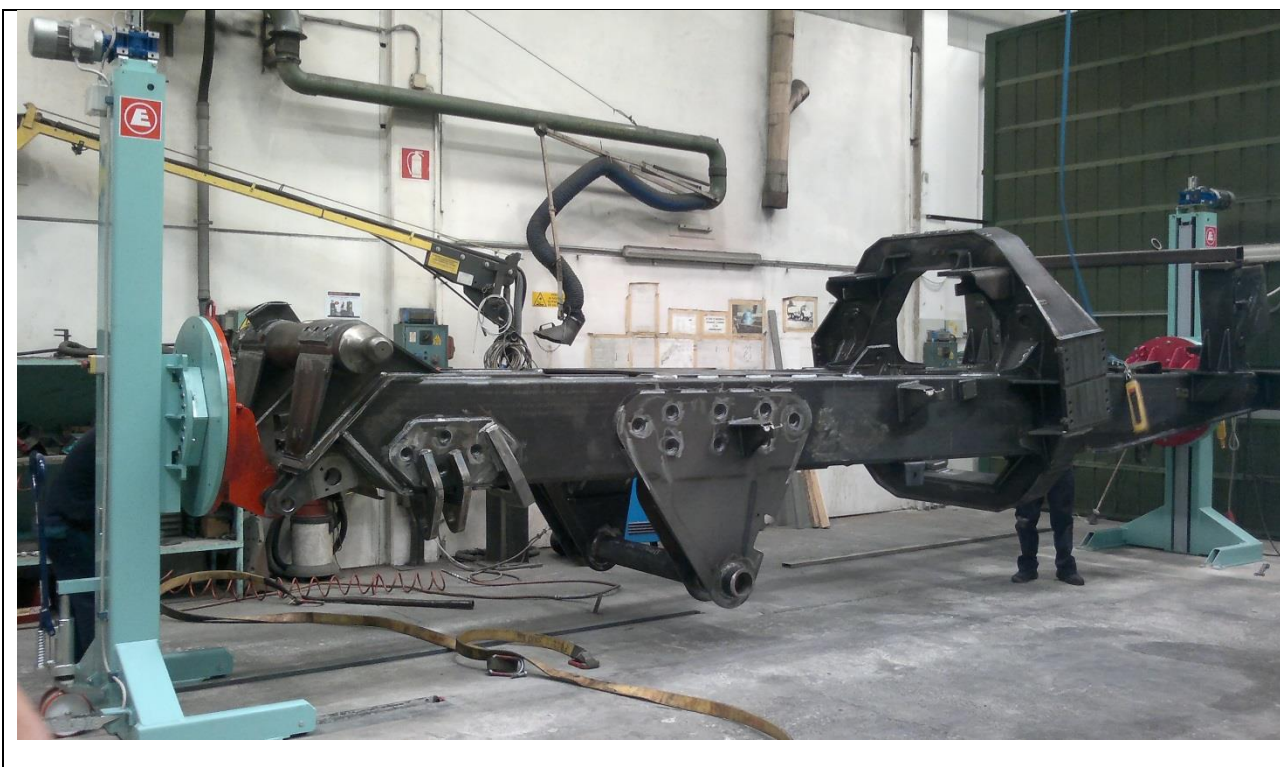

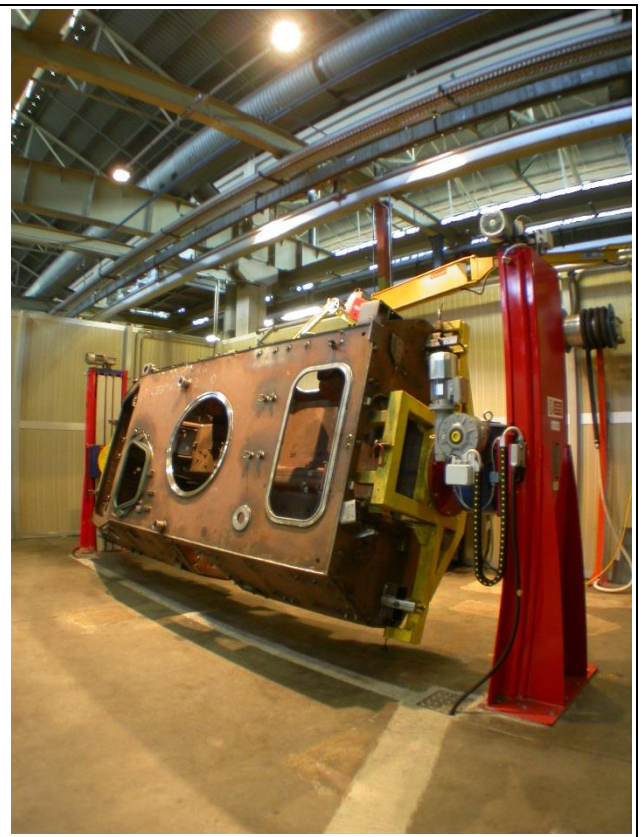
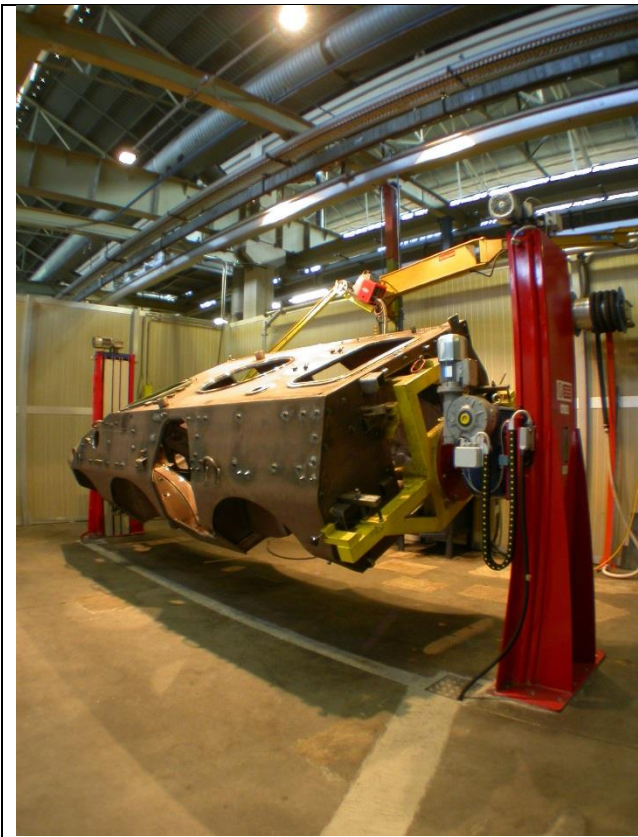
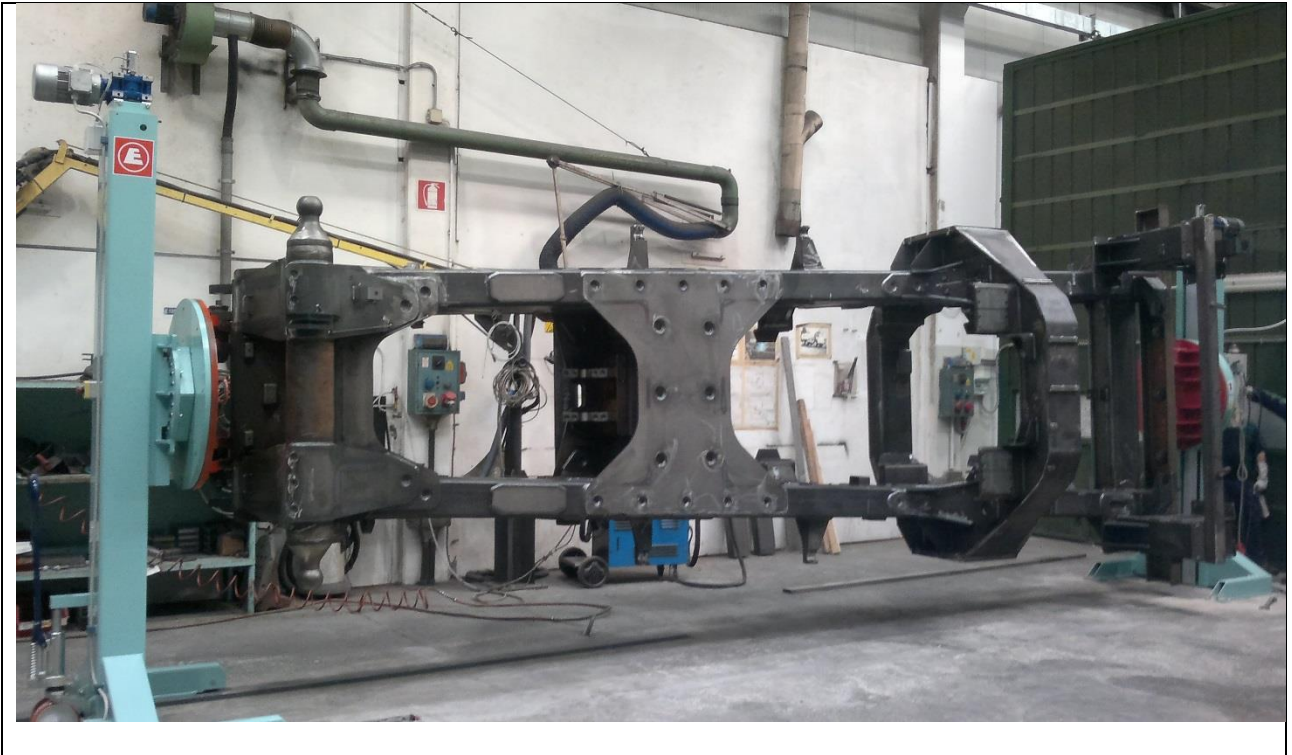

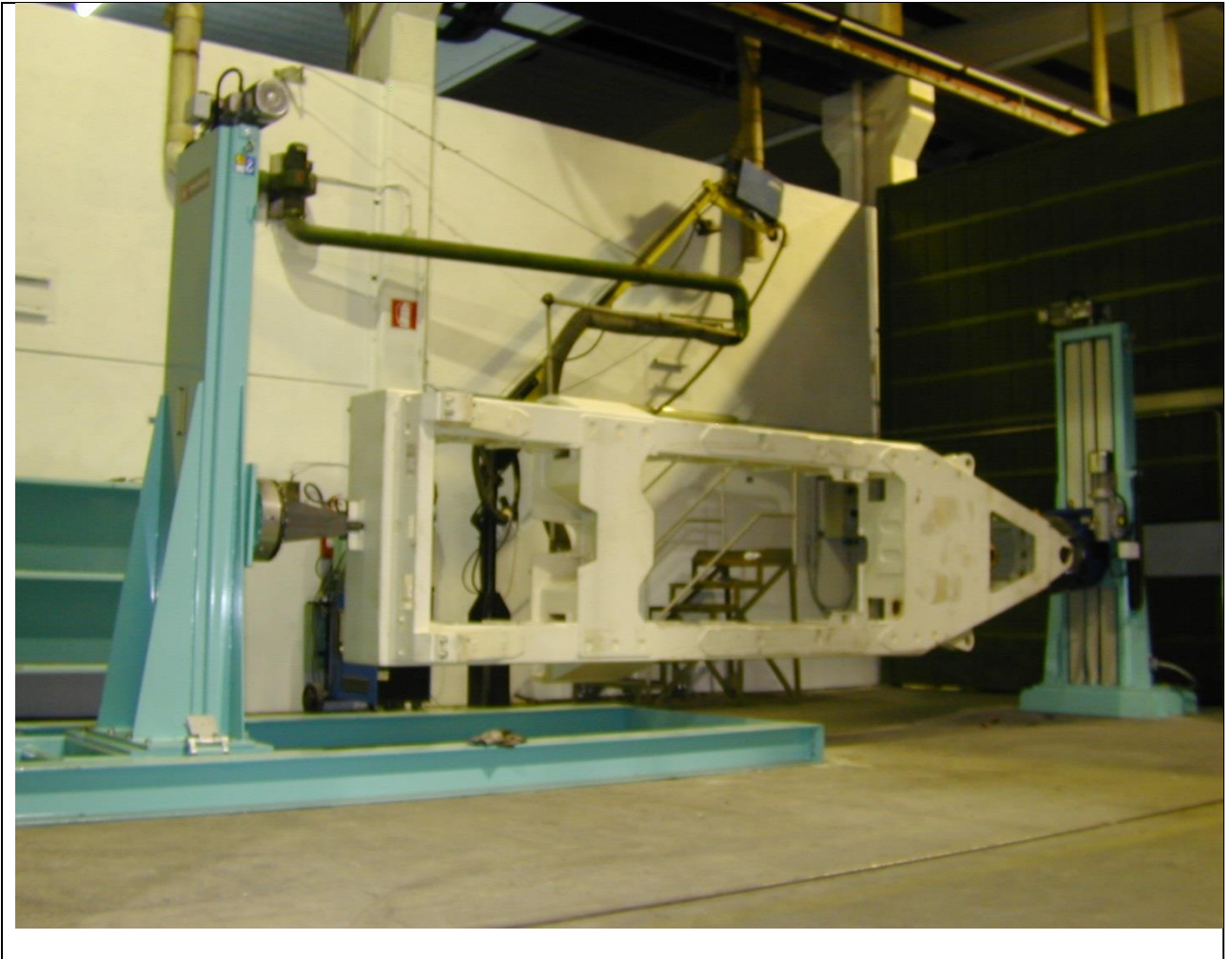



VIEW OF THE CONTROL UNIT INSTALLED ON MASTER JACK

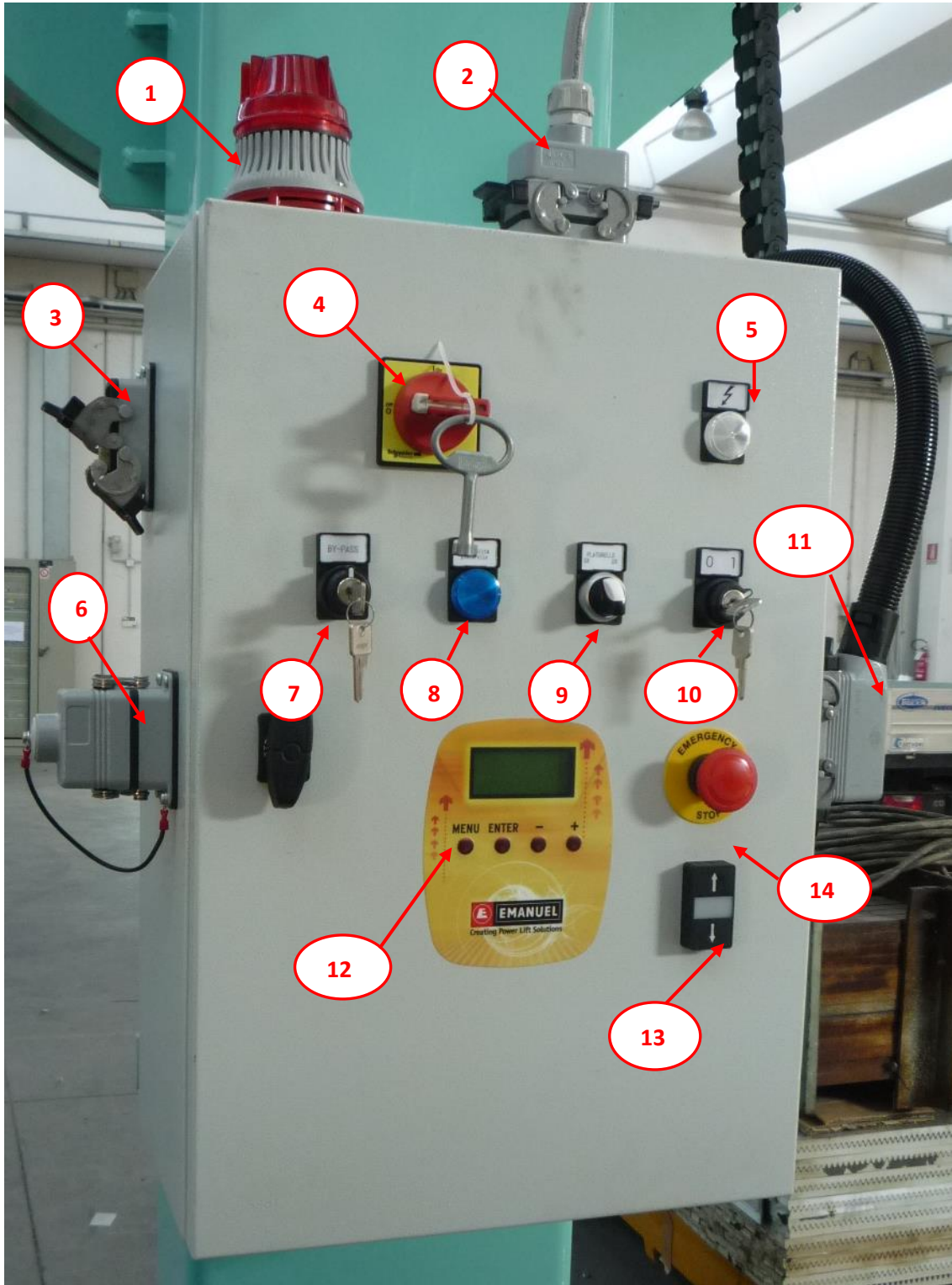

- | | |
|---|--|
| 1. Warning and flashing device | 9. Selector for the right/left rotation |
| 2. Fast connector of master jack | 10. Key selector of tension on control unit |
| 3. Fast connector of slave jack | 11. Fast connector for gear motor and safety sensors designed for the rotation |
| 4. General control switch | 12. Display and keyboard for the functioning unit |
| 5. Warning light for tension | 13. Ascent and descent buttons |
| 6. Fast connector for pendant remote control unit | 14. Emergency button |
| 7. By-pass key selector | |
| 8. Warning light for load in horizontal position | |